

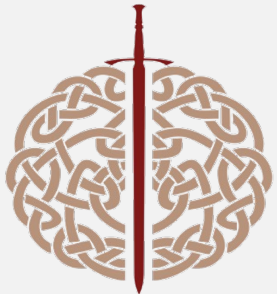

STUYVESANT GARDENS II INTRODUCTION TO PACT PARTNERS

PACT PARTNERS:



AGENDA

- PACT Program Overview
- Update On Charrette Voting
- Social Service Needs Assessment Survey
- Waste Management Plan
- Landscaping Workshop
- Next Steps, Future Meetings & Timeline
- Informational Resources



What Is PACT?

- NYCHA needs \$40 billion to fully renovate and modernize its housing, but the federal government has provided only a fraction of the funding needed.
- Through PACT, developments are included in the Rental Assistance Demonstration (RAD) and convert to a more stable, federally funded program called Project-Based Section 8.
- PACT unlocks funding to complete comprehensive repairs, while keeping homes permanently affordable and ensuring residents have the same basic rights as they possess in the public housing program.

PACT Investments & Improvements



Renovated apartment at Twin Parks West



Site improvements at Baychester



Repaired roof and solar panel system at Ocean Bay (Bayside)



Renovated building entrance at Ocean Bay (Bayside)



How PACT Works

PACT depends on partnerships with private and non-profit development partners, who are selected based on resident input.

COMPREHENSIVE REPAIRS

Development partners bring design and construction expertise. They address all the physical needs at the development.

PROFESSIONAL MANAGEMENT

Property management partners are responsible for the day-to-day operation and upkeep of the buildings and grounds.

ENHANCED SERVICES

Partnerships with social service providers help improve on-site services and programming through input from residents.

PUBLIC CONTROL: NYCHA & RESIDENTS

Your development will remain under public control. After conversion, NYCHA will continue to own the land and buildings, administer the Section 8 subsidy and waitlist, and monitor conditions at the development. Where needed, NYCHA can step in to resolve any issues that may arise between residents and the new property management team.

* PACT uses the Rental Assistance Demonstration (RAD), which was designed to ensure that as developments transition to the Section 8 program, homes remain permanently affordable, and residents have the same basic rights as they possess in the public housing program.

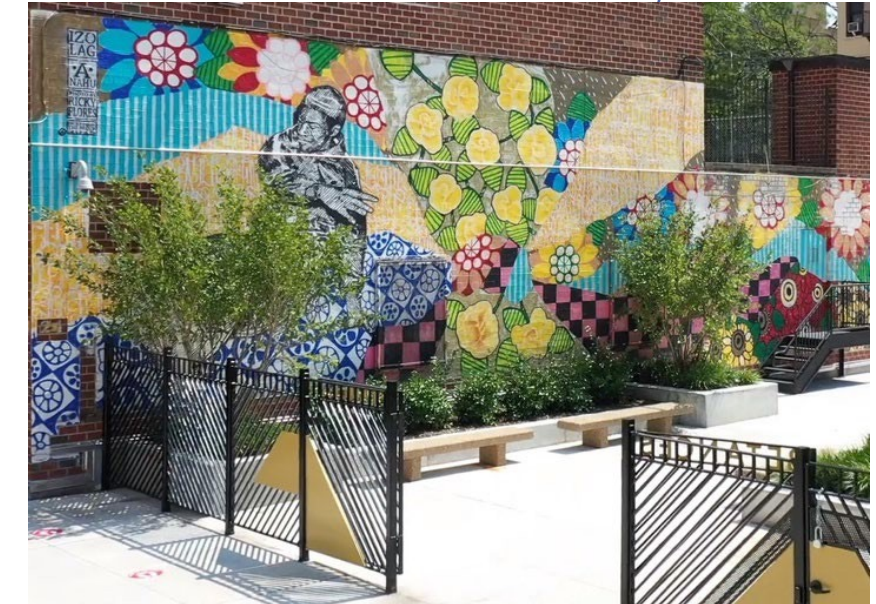

Betances



Ocean Bay (Bayside)



PACT Resident Protections

- Rent will be **30%** of your household's income.*
- You will have the right to **organize**.
- **Resident associations** will continue to receive funding.
- You will have the right to **renew your leases**.
- Your application will **not be re-screened** upon conversion.
- You will be able to **add relatives** onto your leases.
- You will continue to have **succession rights**.
- You will be able to have **grievance hearings**.
- You will have the opportunity to **apply for jobs** created by PACT.

**Exceptions may apply to households who pay flat rent, are current tenant-based Section 8 participants, or a mixed family, as defined by HUD.*

Brief Overview of Timeline



*Rental Assistance Demonstration Program Financing Plan and Section 18 repositioning application.



NYCHA PACT Social Service Needs Assessment Survey

PURPOSE

To improve residents' quality of life through access to social services and resources the PACT team is conducting a survey to solicit feedback from residents to understand which services, opportunities, and programs are important for residents and their households.

METHOD

Door drop paper surveys with flyers.

Targeted outreach via door knocking, phone calls, emails and notices on the door.

GOAL

Feedback from at least 35% of residents

TIMEFRAME

Begin outreach on 3/4/2024. You can even start today by scanning the QR code!

SOCIAL SERVICES NEEDS ASSESSMENT SURVEY

Please help us with identifying the social services needs for your community!

Ways to Take the Survey

- **Via Printed Copy**
Surveys will be delivered to each resident. They may fill out the survey and place it in a drop box outside of one of our following onsite offices:
 - 33 Saratoga Ave, Apt. #6D
 - 671 Willoughby Ave, Apt. #1A
 - 150 Malcolm X Blvd, Apt. #1K
 - 24 Mother Gaston Blvd, Apt. #2B

- **Online via QR Code**

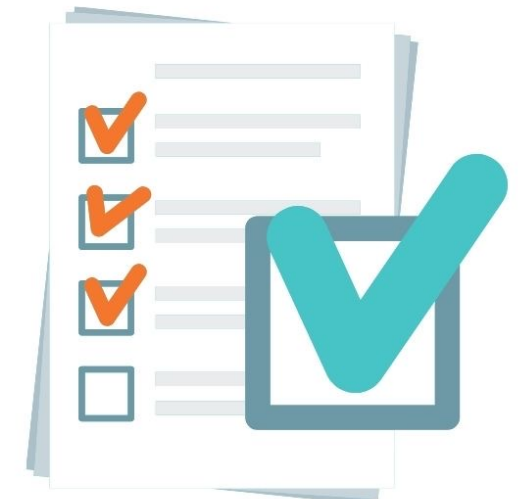

PACT DEVELOPMENT TEAM



For more information or assistance please contact us:
via email: info@ohsgcommunity.com | via phone: (718) 887-8156

Future Resident Meeting Topics

- New Lease Signing
- Construction Readiness
- Hiring & Training Opportunities
- Social Services
- Community Spaces
- Final Scope of Work
- Transition to Section 8



Rendering of Ocean Hill Apartments
** Renderings are subject to change **

Available Resources for Residents



PACT Hotline: (212) 306-4036

Email: PACT@NYCHA.NYC.GOV

Website: <http://on.nyc.gov/nycha-pact>

Contact PACT Resources with questions about:

- PACT Program
- Project-Based Section 8
- How rent will be calculated
- Resident rights and protections

Customer Contact Center (CCC): (718) 707-7771

Contact CCC with questions about:

- Repairs in your apartment or in a public space
- Concerning heat and hot water issues
- For information about housing applications offices

PACT PARTNERS:

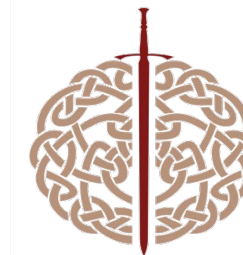

Email: OHSGPACTPARTNER@GMAIL.COM

Website: WWW.OHSGCOMMUNITY.COM

Contact us if you have questions about the following topics:

- Presentation material
- Design and construction
- Future meeting dates and topics
- Hiring and training



Thank You
Questions?

Stuyvesant Gardens II

Apartment Finish Winner! Option 2



STUY GARDENS II - MALCOLM X BLVD
KITCHEN OPTION TWO / OPCIÓN DE COCINA DOS
MATERIALS / MATERIALES

DP KALEL COMPANIES SLM Architecture, P.C. | Design Solutions, Inc.

DP KALEL COMPANIES SLM Architecture, P.C. | Design Solutions, Inc.

2
SUBJECT TO CHANGE
SUBJECTO A CAMBIOS

2
SUBJECT TO CHANGE
SUBJECTO A CAMBIOS

Stuyvesant Gardens II Improved Waste Management

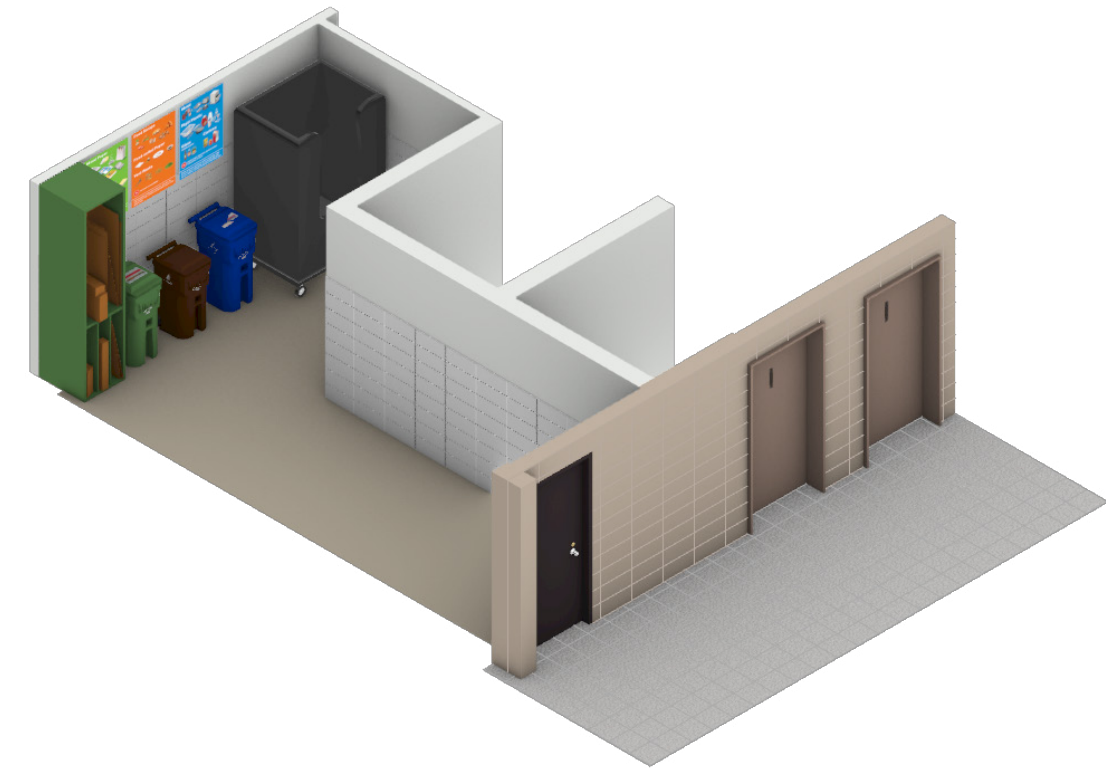

- Introduce **"Recycling Rooms"** for easy disposal of recyclables and bulk items in a central location
- All enclosed waste equipment to deter pests
- Daily (1-2 times/day) removal of all waste
- Security cameras to issue violations

Stuyvesant Gardens II

What You Can't See: Pest Control

Kitchens / Cocinas

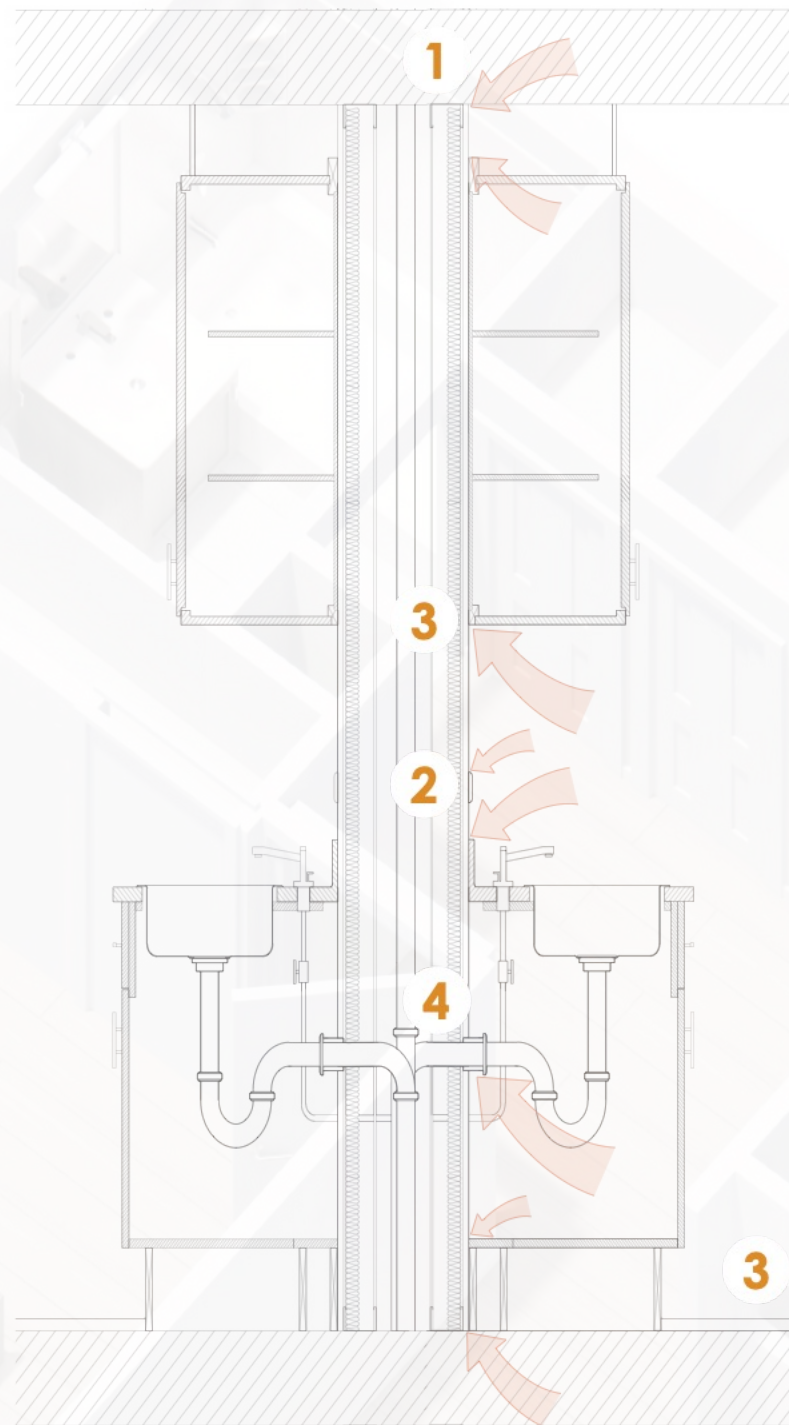

Bathrooms / Baños

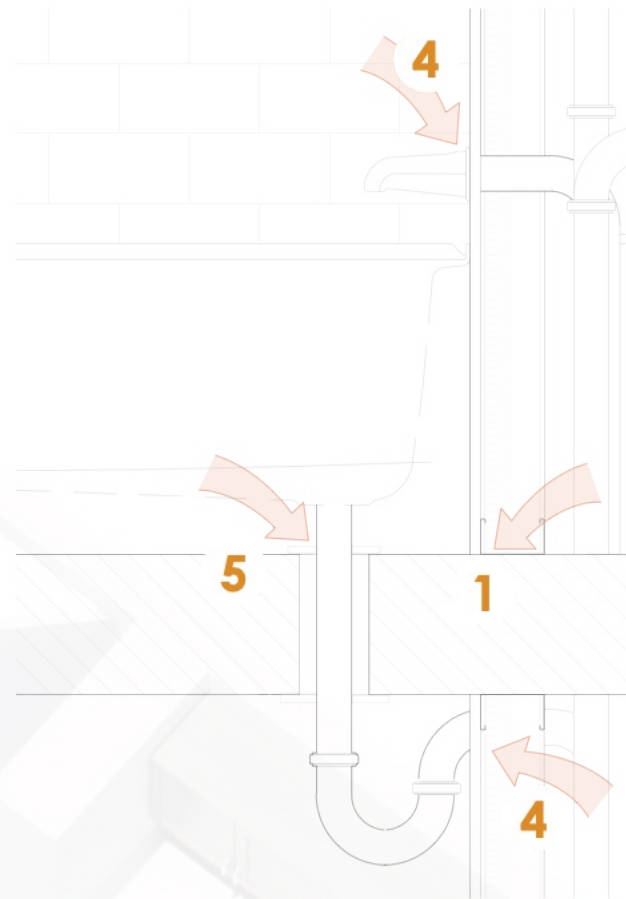

Key Seal Points / Puntos Clave del Sellado:

1. Top and bottom plates
2. Electrical penetrations
3. Back and base of cabinetry
4. Plumbing penetrations in common wall
5. Bathtub drain penetrations

Integrated Pest Management Manejo Integrado de Plagas

- Seal all wall, floor + joint penetrations with low-VOC caulk or other non-toxic methods (window screens, door sweeps, metal plates) to prevent pest entry.
- Install rodent + corrosion-proof material (i.e., copper or stainless-steel mesh or rigid metal cloth) for openings larger than ¼ inch.
- Seal entry points under kitchen + bathroom sinks.
- Install 6" metal flat stock at base of all cabinets

Regular Inspections Inspecciones Periódicas

- Exterminators will regularly service all cellar and common areas, and will be made available to all residents for in-unit treatment on a bi-weekly basis

Stuyvesant Gardens II

Active Security + Site Safety Measures



Comprehensive Security Plan

- New Intercom System
- Cameras in all areas of the building
- Cameras linked to 24/7 off site staff monitoring
- Access Control / Key Fob Entry

Site Safety + Maintenance

- Site lighting overhaul for increased visibility
- Ongoing maintenance of grounds
- Safety surfaces

Site Plan | Plano del Proyecto

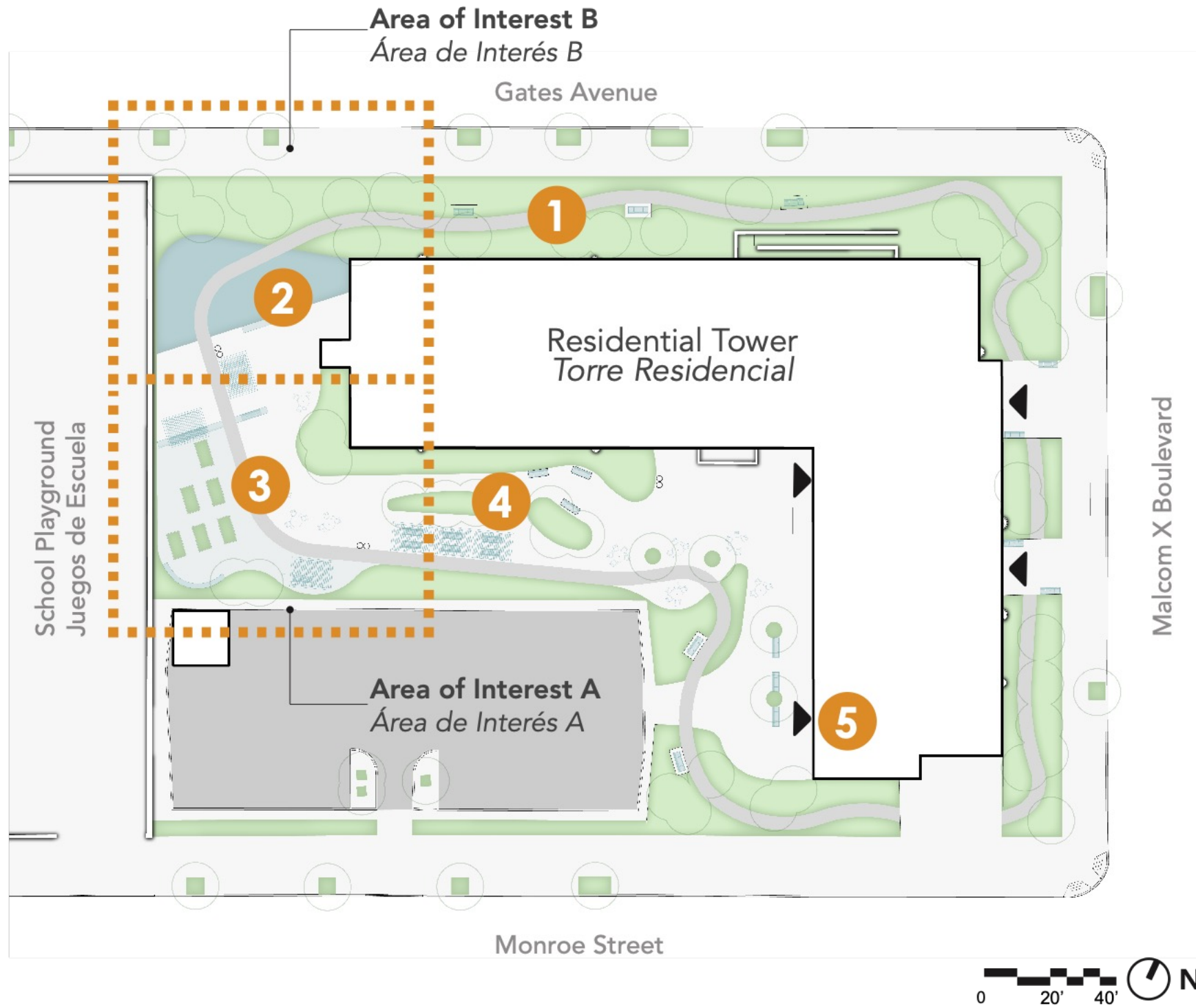

Legend

- 1. Walking Path
- 2. Adult Fitness
- 3. Community Garden
- 4. Seating Area
- 5. Community Center

▼ Entrance

Leyenda

- 1. Sendero
- 2. Entrenamiento para Adultos
- 3. Jardín Comunitario
- 4. Área para Sentarse
- 5. Centro Comunitario

Entrada

**Program is subject to resident feedback
El programa está sujeto a comentarios de los residentes*

Area of Interest A : Social Space | Área de Interés A: Espacio Social

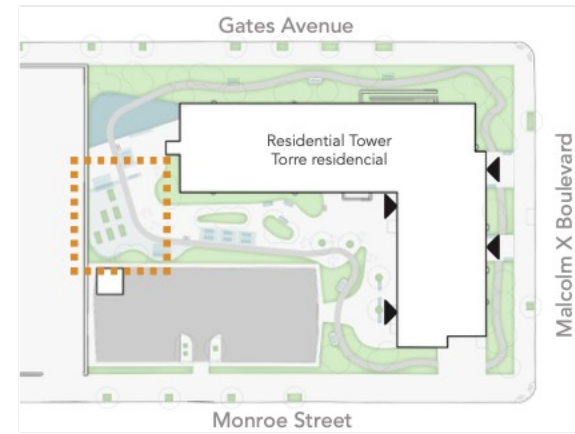
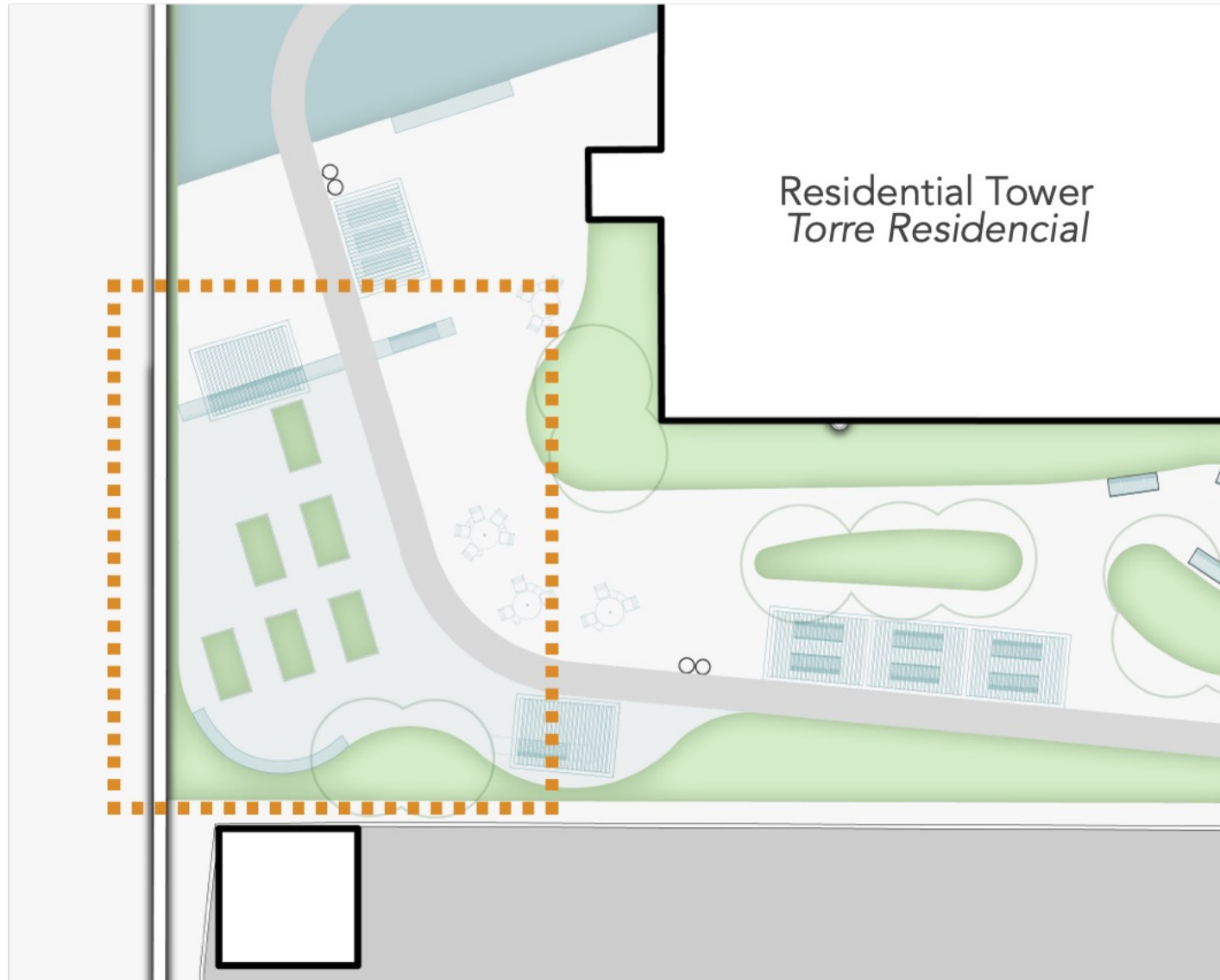

Key Plan | Plano clave

Option 1: Shade Structure / Grills | Opción 1: Estructura con Sombra / Rejillas



Option 2: Gametables | Opción 2: Mesas para Juegos



Option 3: Resident Garden | Opción 3: Jardín para Residentes



All materials shown are representative of the design intent and may not reflect final built condition.
Todos los materiales mostrados son representativos de la intención del diseño y pueden no reflejar la condición final de construcción.

Area of Interest B : Adult Fitness | Área de Interés B: Entrenamiento para Adultos

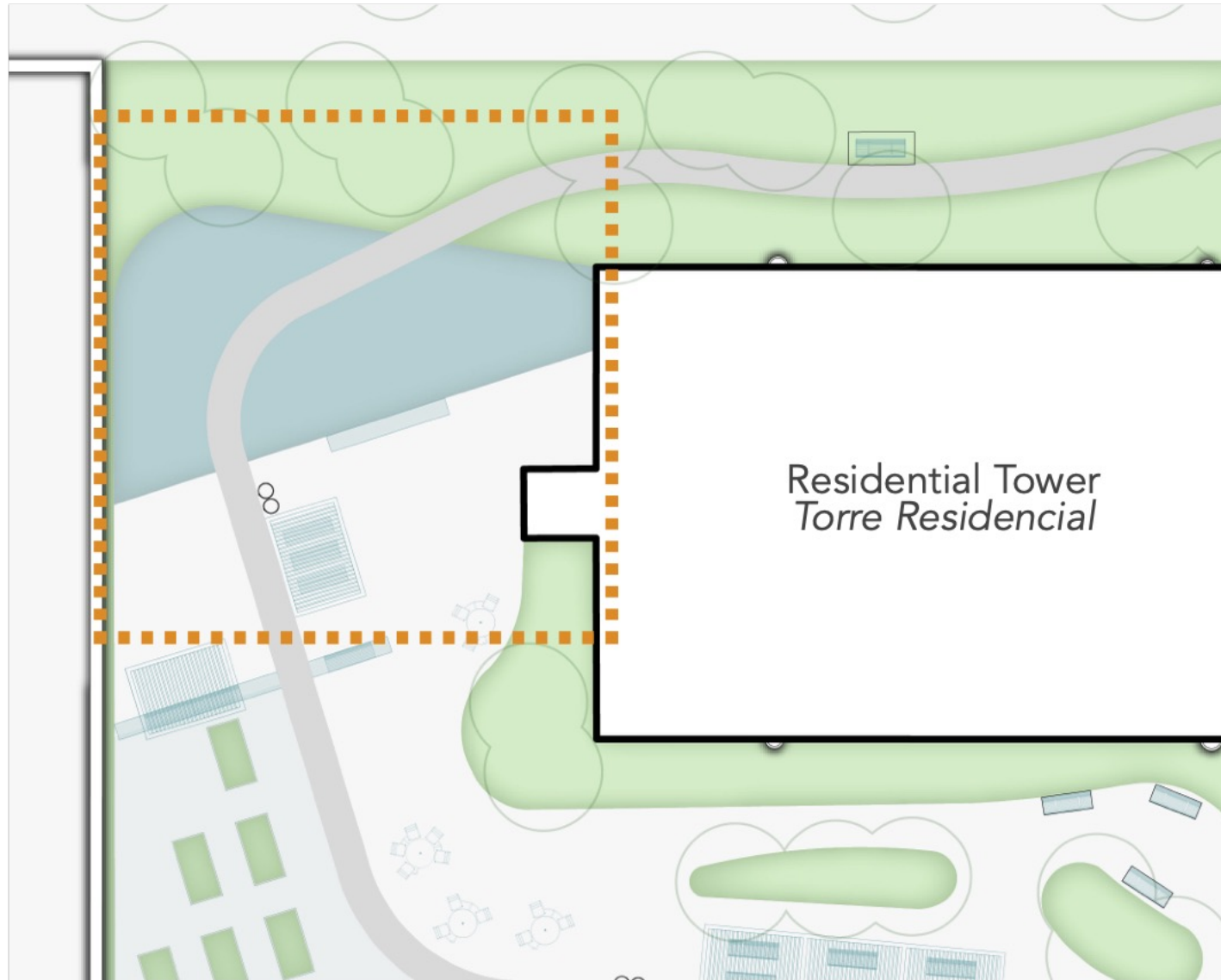

Residential Tower
Torre Residencial



Key Plan | Plano clave

Option 1: Outdoor Seating | Opción 1: Asientos al Aire Libre



Option 2: Swings / Exercise Equipment | Opción 2: Columpios / Equipo de Ejercicio



Option 3: Flexible Space | Opción 3: Espacio Flexible



Stuyvesant Gardens II

Social Spaces | Espacios Sociales

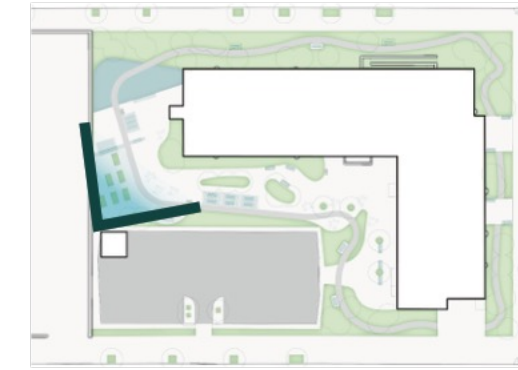

Key Plan | Plano clave